





<h1>3</h1>				
	S 70 T	WS 70 E	S 100 T	WS 100 E
Dimensions (ø) [mm]	70	150	100	190
Designation	plug	debris sieve	plug	debris sieve
DN	70	70	100	100
Material	tombac	stainless steel	tombac	stainless steel
Weight [kg]	0.6	0.6	0.9	0.7
Order no.	57468	51973	57462	51974

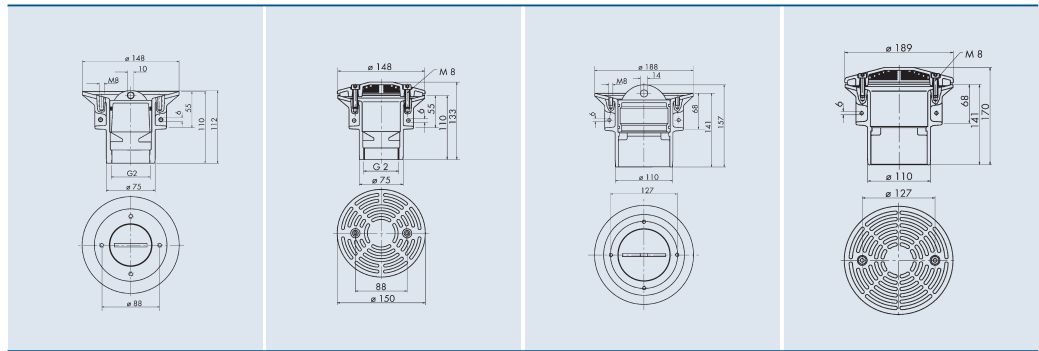

<h1>2</h1> (optional)		
	FK 70 T	FK 100 T
Dimensions (ø) [mm]	148 x 26	188 x 35
Designation	liner clamping flange	liner clamping flange
DN	70	100
Material	tombac	tombac
Weight [kg]	1.1	1.4
Order no.	51108	51117

<h1>1</h1>		
	B 70 T	B 100 T
Dimensions (ø x H) [mm]	70 x 110	100 x 141
Designation	concrete part	concrete part
DN [mm] / [inch]	70 / 2"	100
Material	tombac	tombac
Weight [kg]	2.1	3.2
Order no.	57471	57467



<h1>3</h1>				
	S 70 T	WS 70 E	S 100 T	WS 100 E
Dimensions (ø) [mm]	70	150	100	190
Designation	plug	debris sieve	plug	debris sieve
DN	70	70	100	100
Material	tombac	stainless steel	tombac	stainless steel
Weight [kg]	0.6	0.6	0.9	0.7
Order no.	57468	51973	57462	51974

<h1>2</h1> (optional)		
	FK 70 T	FK 100 T
Dimensions (ø) [mm]	148 x 26	188 x 35
Designation	liner clamping flange	liner clamping flange
DN	70	100
Material	tombac	tombac
Weight [kg]	1.1	1.4
Order no.	51108	51117

<h1>1</h1>		
	B 70 T	B 100 T
Dimensions (ø x H) [mm]	70 x 110	100 x 141
Designation	concrete part	concrete part
DN [mm] / [inch]	70 / 2"	100
Material	tombac	tombac
Weight [kg]	2.1	3.2
Order no.	57471	57467