



SYSTEM 1 – »MATRIX 25«

Fun for everyone: Five times five pumps, each with Komet nozzles and LED spotlights can be individually controlled via DMX technology and ensure a firsthand water experience. The Nozzle Chambers make an invisible and easy installation possible. Such a matrix can generate different water compositions such as a pyramid or a suspended carpet in a wide variety of colours.

The following OASE products are used amongst others:

- Varionaut 2 (p. 126)
- BEST LED (p. 88)
- Comet Long (p. 94)
- Nozzle Chamber Single (p. 130)
- Easy Control (p. 160)

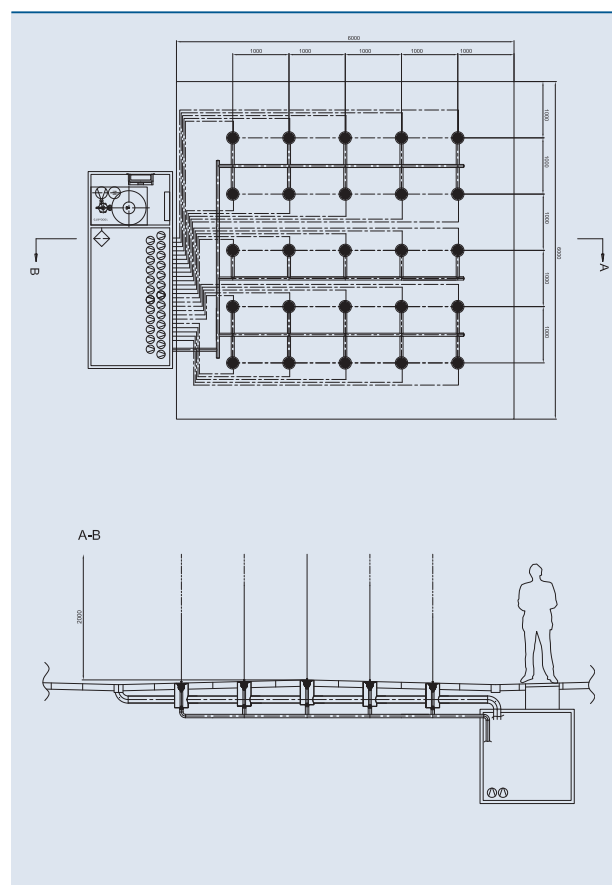



SYSTEM 2 – »LINE 5«

A lively water feature that makes an impression:

Here, five Nozzle Stars LED generate a sinus wave, illuminated in the colours of the rainbow. The whole is powered by the Varionaut 1, which, in this case as 24V submersible motor pump, can be housed directly in the pool – in conformance with the erector specification DIN VDE 0100 Part 702.

The following OASE products are used amongst others:

- **Varionaut 1** (p. 124)
- **Nozzle Star LED** (p. 90)
- **Easy Control** (p. 160)

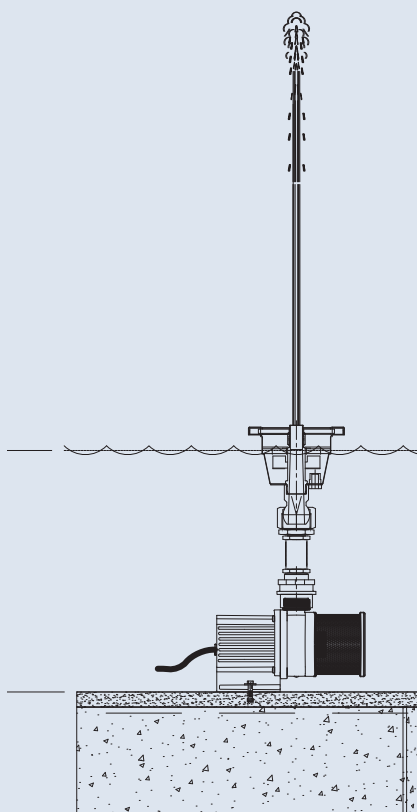

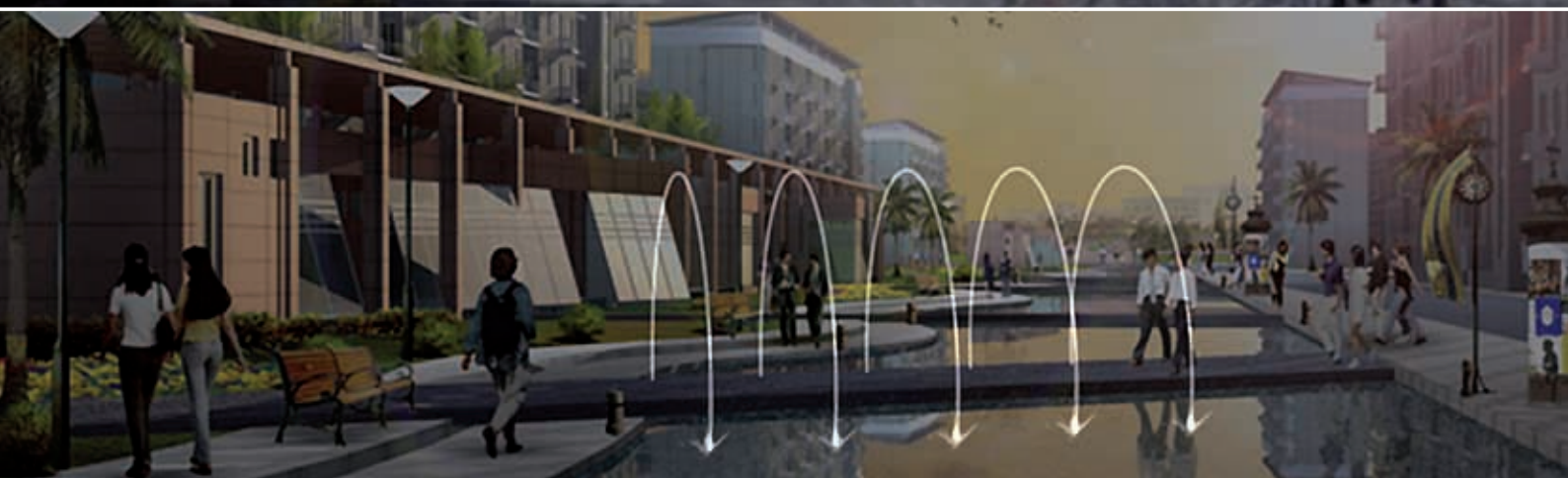
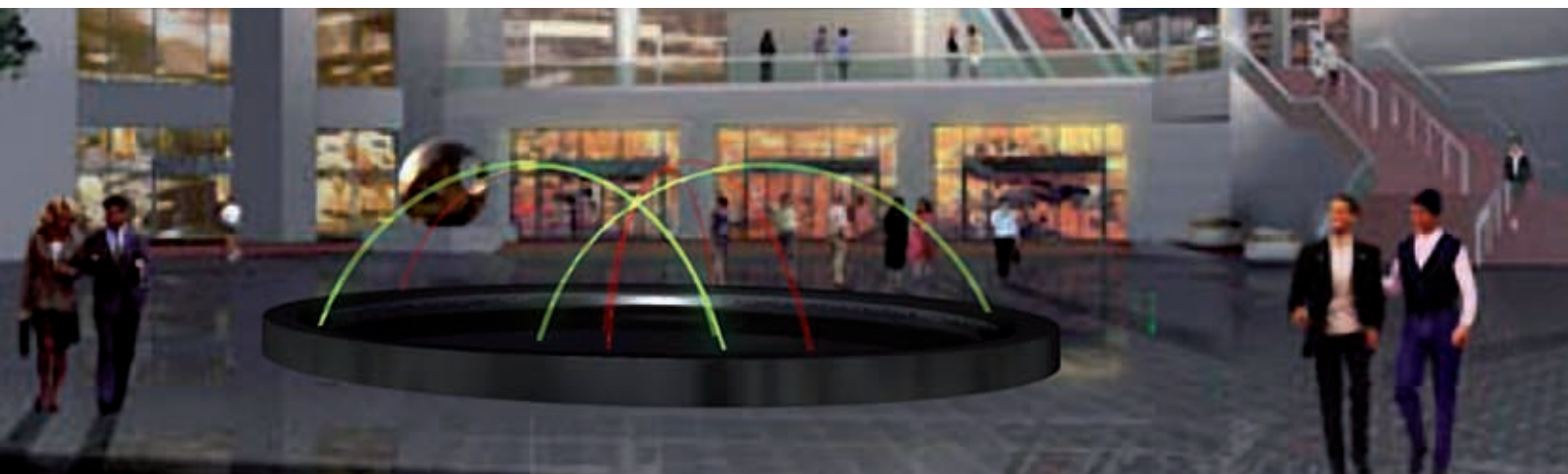

SYSTEM 3 – »JJ-RAINBOW STAR 5«

Impressive framing with many application possibilities: Whether as water tunnel or compact pool installation – the Jumping Jets with LED lighting in rainbow colours always ensure surprising accents.

The following OASE products are used amongst others:

- Jumping Jet Rainbow Flash (p. 20)
- Jumping Jet Rainbow Star (p. 22)

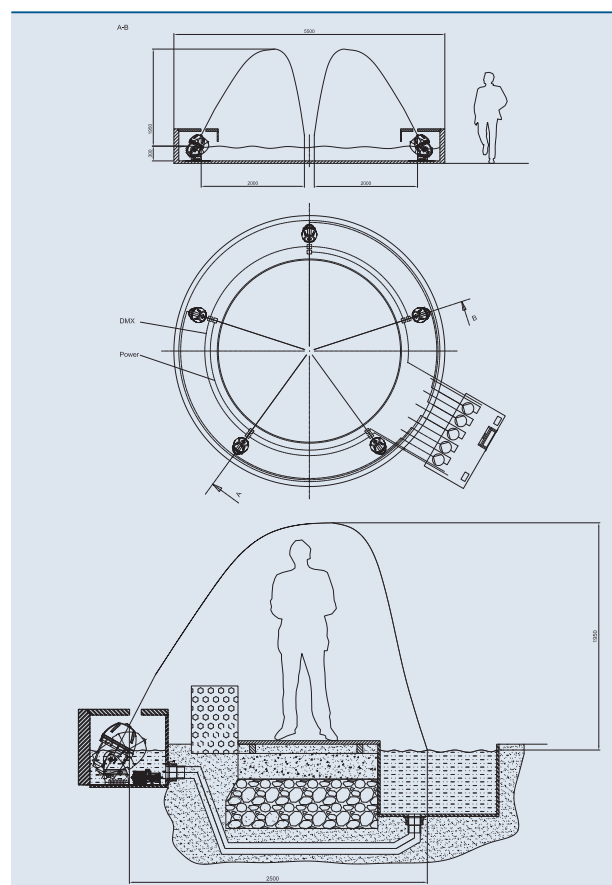

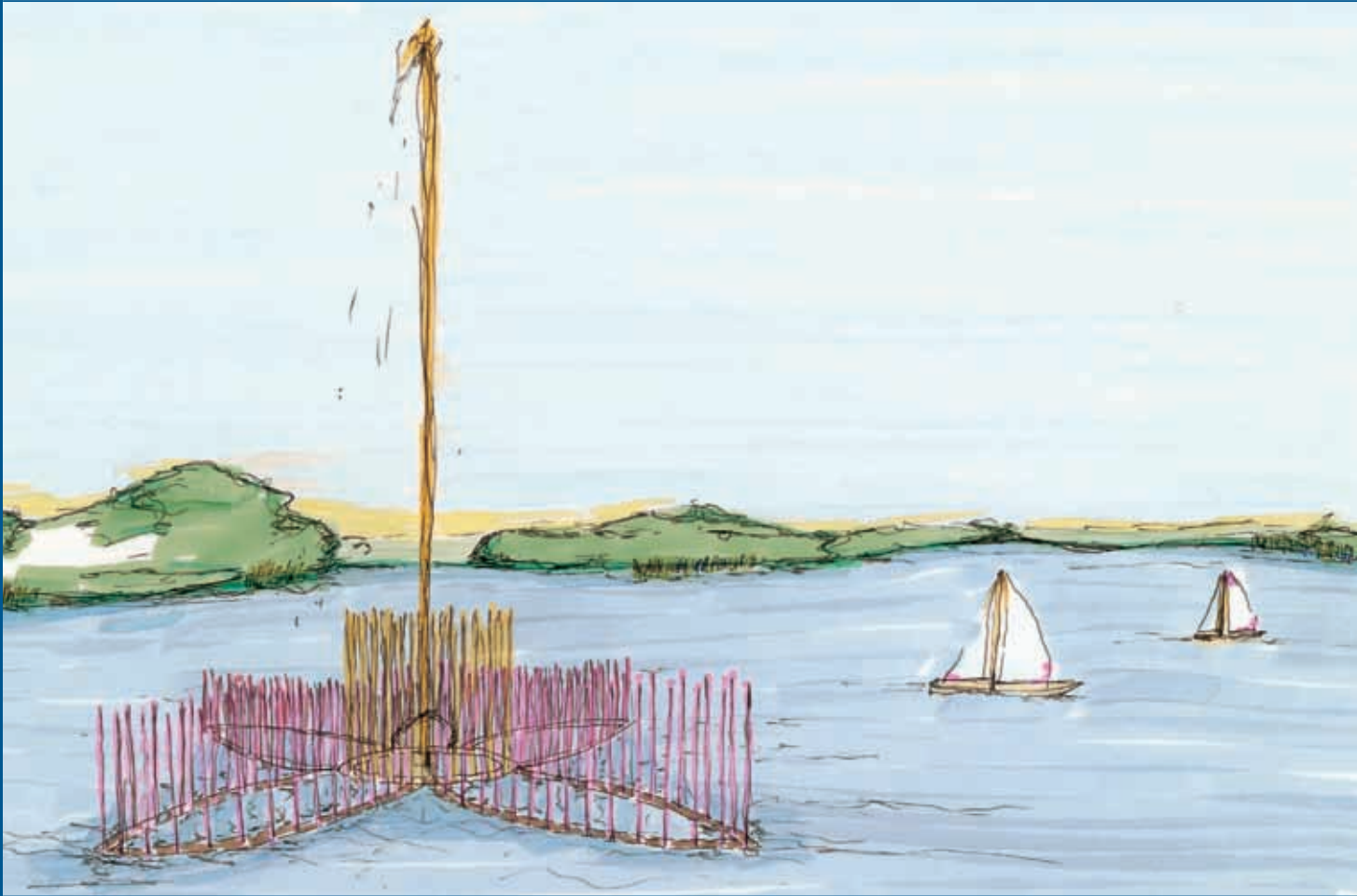

SYSTEM 4 – » FLEXY FLOWER «

Creativity without limits: With our Flexy Jets and in combination with the new Midi or Maxi floating fountains many design ideas can be realised – for maximum freedom of design.

The following OASE products are used amongst others:

- Flexy Jet (p. 64)
- Midi II (p. 66)
- Maxi II (p. 66)
- Varionaut-Pumps (p. 124)
- Nozzle Star LED (p. 90)

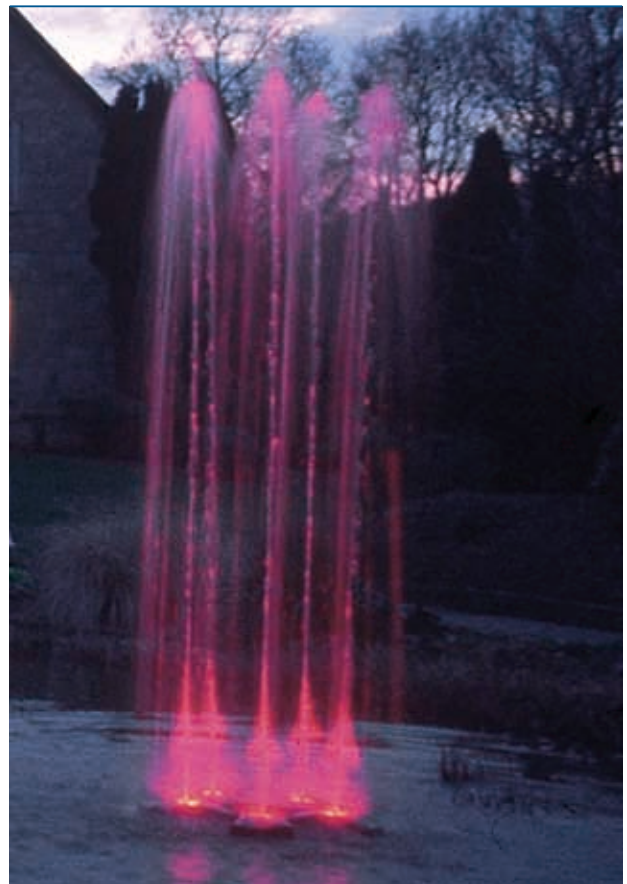

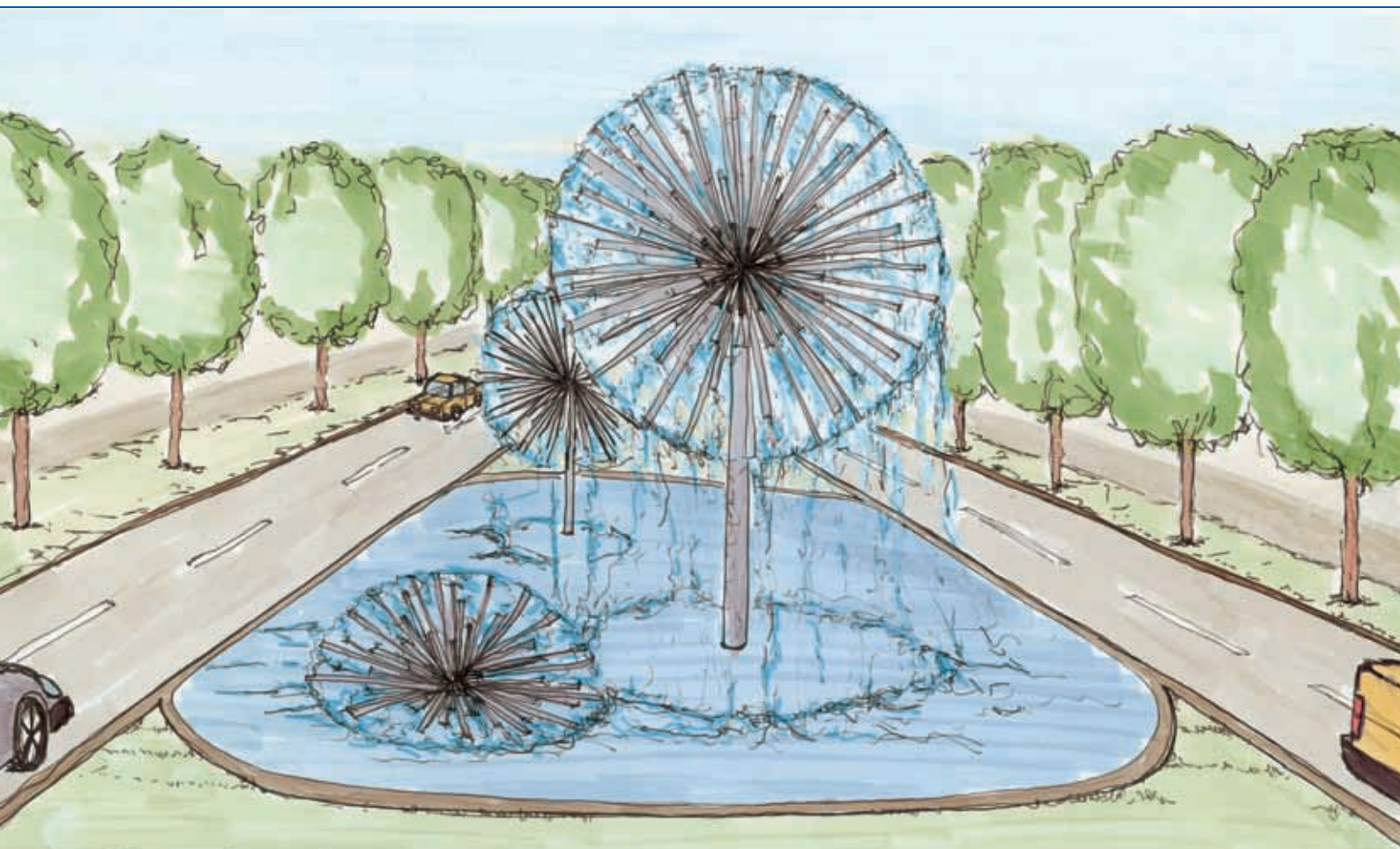

SYSTEM 5 – » WATER SPHERES «

A very special highlight for all waters: In whole or half versions our water spheres offer the effect of a sculpture that is integrated in nature. They ensure mood-setting accents particularly when illuminated.

The following OASE products are used amongst others:

- Water spheres (p. 97)
- Twin Star LED (p. 91)
- Halogen illumination (p. 70)

